

Pyrometer with focusable optics for non-contact temperature measurements on metals, ceramics, graphite etc. between 300 and 3300°C

IS 140 • IGA 140

IS 140-PB • IGA 140-PB



- Short response times < 1 ms
optional 500 µs
- Extremely small spot sizes, min 0.35 mm
- Built-in digital display
- Optimized thru-lens view finder,
laser targeting light or video module
- Test current output
- Housing with precision mounting rail for
safe mounting and accurate alignment
- Interface RS232 / RS485 switchable
or built-in Profibus-DP interface
- Focusable optics



The pyrometers **IS 140**, **IGA 140**, **IS 140-PB** and **IGA 140-PB** are digital, highly accurate pyrometers for non-contact temperature measurement on metals, ceramics, graphite etc.

The types **IS 140** and **IGA 140** are equipped with RS232 and RS485 serial interfaces (switchable). This enables additionally the reading of temperature and pyrometer parameters via the provided InfraWin PC-software. If necessary the parameters also can be changed via PC.

The **PB types** are equipped with a Profibus-DP interface and can be easily integrated in existing Profibus systems. The GSD file (part of stan-

dard delivery) offers a selection of 5 different module configurations corresponding your requirements. The project planning can be done with any project tool.

For optimal match of the instrument to the application 3 different focusable optics with extremely small spot sizes are available.

The pyrometer parameters can be selected via the integrated key pad, the settings are indicated on the built-in LC-Display. In measuring mode the actual temperature is indicated.

A laser targeting light, a thru-lens view finder or a color camera mod-

ule (not for PB types) for exact alignment of the pyrometer is available. The color camera module enables the optical alignment of the pyrometer to the measuring object via video screen or monitor.

Typical applications:

- preheating
- annealing
- tempering
- welding
- forging
- hardening
- sintering
- melting
- soldering
- rolling
- brazing
- normalizing

Technical Data

Temperature ranges:	see reference numbers, other temperature ranges on request
Subrange:	any range adjustable within the temperature range, minimum span 51°C
Spectral ranges:	IS 140 / IS 140-PB: 0.7 to 1.1 µm IGA 140; IGA 140-PB: 1.45 to 1.8 µm
Signal processing:	photoelectric current, digitized immediately
Accuracy: ($\epsilon = 1, t_{90} = 1 \text{ s}, T_{\text{amb.}} = 23^\circ\text{C}$)	below 1500°C: 0.3% of measured value in °C + 1°C above 1500°C: 0.5% of measured value in °C
Repeatability:	0.1 % of measured value in °C + 1°C
Resolution:	interface and display: 0.1°C, analog output: < 0.1 % of temperature range
Response time t_{90} :	< 1 ms, adjustable up to 10 s ("L" temperature ranges: with dynamical adaption at low signal levels)
Emissivity ϵ :	10 to 100% adjustable in steps of 0.1%
Analog output:	linear 0 to 20 mA or 4 to 20 mA, DC, switchable; load max. 500 Ohm
Test current output:	fixed 10 mA (for 0 to 20 mA analog output) or fixed 12 mA (for 4 to 20 mA analog output)
Power supply:	24 V AC/DC (12 to 30 V AC/DC) (AC: 48 to 62 Hz)
Power consumption:	max. 2 VA
Serial interface:	switchable inside the pyrometer: RS232 or RS485 addressable, half duplex; baud rate up to 115 kBd
Parameters:	adjustable at the instrument or via serial interface: emissivity; response time; analog output; address; baud rate; waiting period t_w ; temperature unit °C or °F; setting of the maximum value storage; temperature sub range
Maximum value storage:	single or double storage; cleared by: preselected time interval; external deletion contact or via digital interface; automatically with the next measuring object
Isolation:	power supply, digital interface, analog output are galvanically isolated against each other and housing
Sighting:	laser targeting light (max. power level < 1 mW, $\lambda = 630\text{-}680 \text{ nm}$, CDRH class II) or thru-lens view finder
Protection class:	IP65 (DIN 40 050)
Ambient temperature:	0 to 70°C at housing
Storage temperature:	-20 to 80°C
Weight:	approx. 550 g
CE-label:	according to EU directives about electromagnetic immunity



Technical data video module (only TV version):

Video signal:	FBAS-Signal approx. 1 V _{pp} at 75 Ohm, PAL (B), 50Hz (optional NTSC (M), 60 Hz)
Resolution:	628 x 582 Pixel (510 x 492 at NTSC)
Illumination control:	automatic or adjustable (via keyboard or software)
Field of view:	approx. 3.5% x 5% of the adjusted measuring distance
Connection video signal:	SCART- or Cinch plug (monitor's side); separate round plug (at the pyrometer); connections galvanically isolated; video signal selectable when more than one pyrometer with TV output is used
Date / time:	Real time clock with about 3 days buffer (GoldCap capacitor, free of harmful substances)
Screen display:	circular target marker; instrument's number or text to your choice (max. 12 characters); time and / or date (switchable); measured temperature, emissivity

Pyrometer Alignment

For exact aiming to the object different alignment systems are available:

- **Laser targeting light:** the laser targeting light is a red laser beam used to align the pyrometer at a target. The laser marks the center of the measuring spot. The laser targeting light can be used during operation without effecting the measurement.
- **Thru-lens view finder** (not for PB types): the view finder can be used to align the measured object through direct observation. The view finder is true-sided and parallax-free; a circle marks the position of the measuring area,
- **Color camera module:** The camera module enables the optical alignment of the pyrometer to the measuring object via video screen or monitor.

IS 140; IGA 140

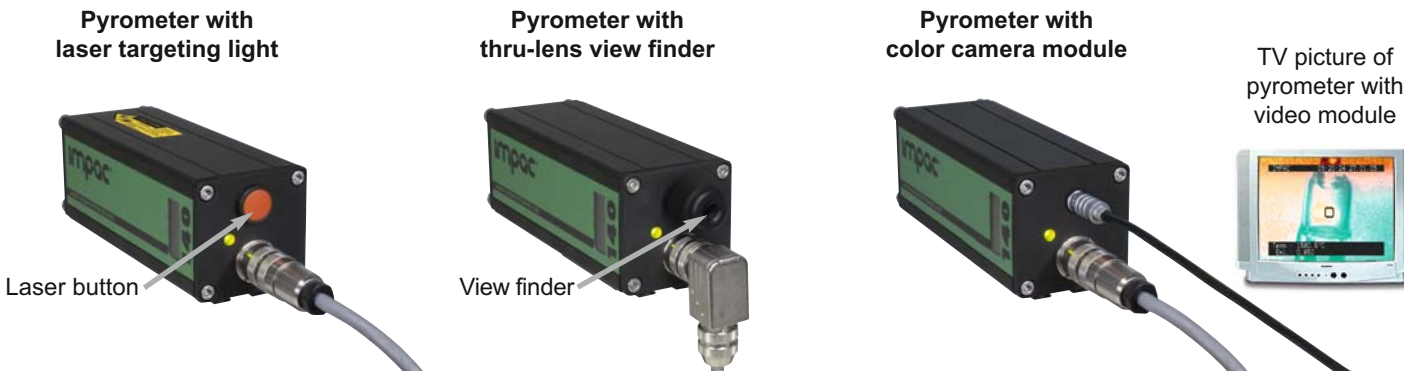

Advantages of the Digital Signal Processing

The signal processing of series 140 pyrometers is fully digital, i.e. the detector signal is digitized immediately and digitally processed. With this technique an extremely high accuracy and repeatability as well as very long measuring ranges are achieved.

Accuracy:	The high accuracy is achieved by the digital linearization of the sensor output as well as the digital compensation of the ambient temperature.
Temperature range:	Due to the digital technique the user can set any temperature sub range within the full temperature range. The minimum span of the sub range is 51°C. The analog measuring output corresponds automatically to the selected sub range. This setting of a sub range can be done without recalibration of the pyrometer and does not effect the high accuracy and repeatability. As almost any sub range is adjustable, the storage of spare instruments or the replacement of other pyrometers is simplified.
Output:	The analog measuring outputs 0 to 20 mA or 4 to 20 mA are selectable as well as the serial digital interfaces RS232 or RS485. Additionally the interface allows the controlling of the pyrometer via PC.
Bus control:	The serial interface RS485 or Profibus-DP facilitates the integration of the pyrometer into existing field bus systems.
Calibration:	If a suitable calibration source is available, a calibration of the pyrometers can be done via serial interface without opening the housing.

Optics

Focusable optics		
	measuring distance a [mm]	spot size M_{90} [mm]
Optics 1	a = 130 mm	0.35
	a = 160 mm	0.5
	a = 200 mm	0.7
Optics 2	a = 190 mm	0.5
	a = 300 mm	0.8
	a = 420 mm	1.3
Optics 3	a = 340 mm	0.9
	a = 2000 mm	6.5
	a = 4000 mm	15

Aperture D (depends on the objective distance):
 Basic temperature range up to 1500°C: 14 ... 16 mm;
 Basic temperature range above 1500°C: 8 ... 9 mm

The series 140 pyrometers are available with 3 different focusable optics. They offer the smallest possible spot size at any distance. The adjustment can be done easily without additional tools with help of the „turn and clamp“ mechanism (one hand). The spot sizes are shown in the following table (all distances are measured from the front of the lens).

The different optics are exchangeable without recalibration of the pyrometer.

For spot sizes between those in the table, values can be found by interpolation.

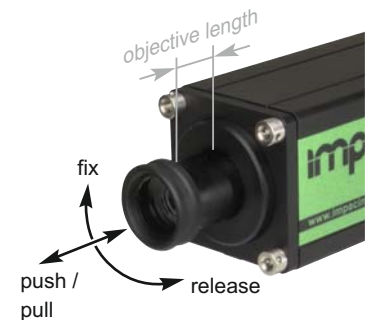

Reference Numbers IS 140; IGA 140

IS 140	Laser targeting	View finder	PAL camera module	NTSC camera module
MB 14: 550 to 1400°C	3 875 100	3 875 110	3 882 100	3 882 110
MB 16: 600 to 1600°C	3 875 120	3 875 130	3 882 120	3 882 130
MB 18: 650 to 1800°C	3 875 140	3 875 150	3 882 140	3 882 150
MB 18L: 550 to 1800°C	3 875 200	3 875 210	3 882 200	3 882 210
MB 25: 750 to 2500°C	3 875 160	3 875 170	3 882 160	3 882 170
MB 33: 900 to 3300°C	3 875 180	3 875 190	3 882 180	3 882 190

IGA 140	Laser targeting	View finder	PAL camera module	NTSC camera module
MB 13: 300 to 1300°C	3 875 300	3 875 310	3 882 300	3 882 310
MB 13.5L: 250 to 1350°C	3 875 360	3 875 370	3 882 360	3 882 370
MB 18: 350 to 1800°C	3 875 320	3 875 330	3 882 320	3 882 330
MB 25: 450 to 2500°C	3 875 340	3 875 350	3 882 340	3 882 350
MB 20L: 300 to 2000°C	3 875 380	3 875 390	3 882 380	3 882 390
MB 25L: 350 to 2500°C	3 875 400	3 875 410	3 882 400	3 882 410
MB 30L: 300 to 3000°C	–	3 875 470	–	–

Ordering note:

When ordering please select one focusable optics.
 A connection cable (and a video cable for the instruments with video module) is not included in scope of delivery and has to be ordered separately.

Ordering example:

3 875 150 IS 140 with thru-lens view finder, focusable optics 2, temperature range 650 to 1800°C
 3 820 530 connection cable, length 10 m, with 90° connector

Scope of delivery: Pyrometer with one optics, works certificate with 3 measuring points, *InfraWin* operating and analyzing software

Dimensions IS 140; IGA 140

Pyrometer with thru-lens view finder

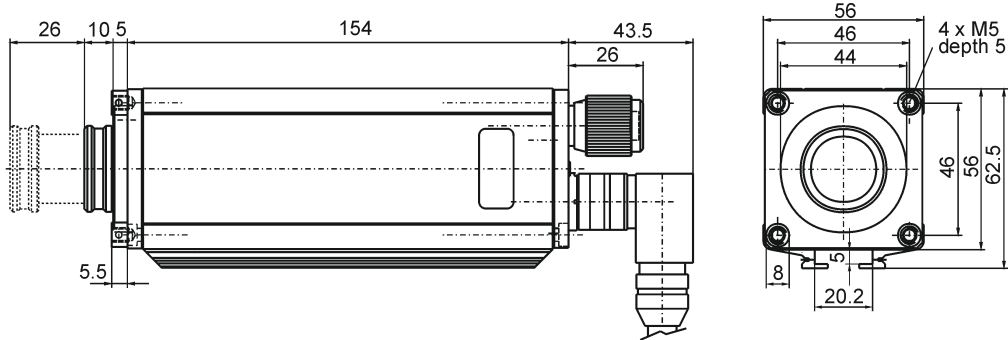

Pyrometer with laser targeting light

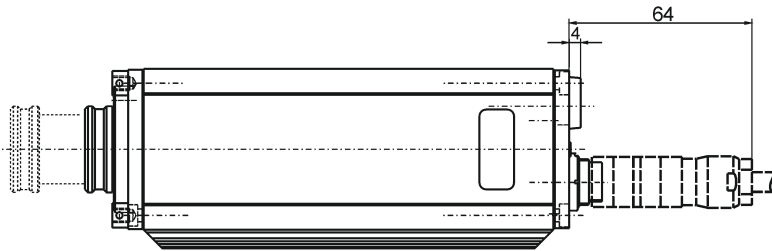

Pyrometer with video module

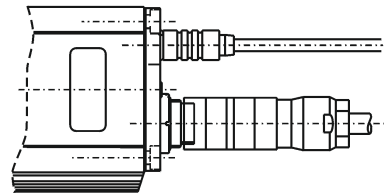

All dimensions in mm

Dimensions IS 140-PB; IGA 140-PB

Pyrometer with thru-lens view finder

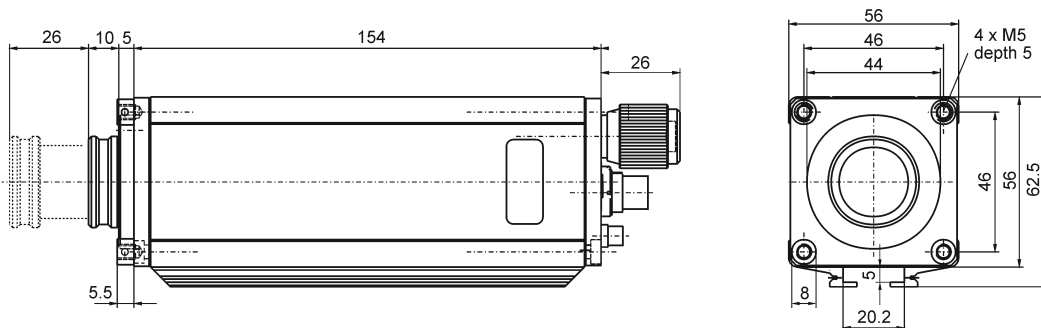

Pyrometer with laser targeting light

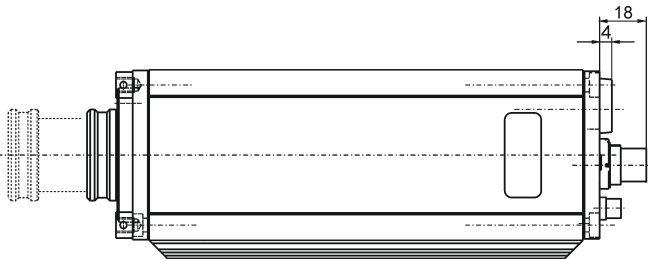

Straight Profibus connector

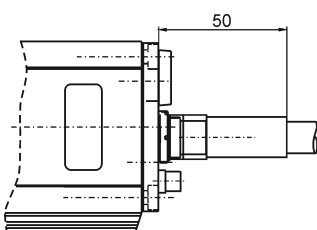

Angulated Profibus connector

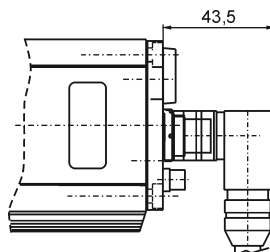

All dimensions in mm

Technical Description Profibus Pyrometers

the Profibus versions **IS 140-PB** and **IGA 140-PB** are digital, highly accurate pyrometers with **Profibus-DP interface** instead of the serial interface RS232 or RS485.

The pyrometers can be easily integrated in existing Profibus systems via the built-in Profibus-DP interface. The GSD file (part of standard delivery) offers a selection of 5 different module

configurations corresponding your requirements. The project planning can be done with any project tool.

Technical Data Profibus pyrometers (different to IS 140; IGA 140)

Analog output:	linear, 0 ... 20 mA or 4 ... 20 mA (specify when ordering); load max. 500 Ω
Interface:	Profibus-DP; connector, male / female: M12 x 1, B-coded; baud rate 9600 Bd to 12 MBd
Parameters:	adjustable via Profibus interface: emissivity, response time, setting of the maximum value storage laser targeting light, temperature sub range

Reference Numbers Profibus Pyrometers

IS 140-PB	with laser targeting light	with view finder	IS 140-PB	with laser targeting light	with view finder		
MB 14:	550 to 1400°C	3 876 100	3 876 110	MB 13:	300 to 1300°C	3 876 300	3 876 310
MB 16:	600 to 1600°C	3 876 120	3 876 130	MB 18:	350 to 1800°C	3 876 320	3 876 330
MB 18:	650 to 1800°C	3 876 140	3 876 150	MB 25:	450 to 2500°C	3 876 340	3 876 350
MB 25:	750 to 2500°C	3 876 160	3 876 170	MB 13.5 L:	250 to 1350°C	3 876 360	3 876 370
MB 33:	900 to 3300°C	3 876 180	3 876 190	MB 20 L:	300 to 2000°C	3 876 380	3 876 390
MB 18 L:	550 to 1800°C	3 876 200	3 876 210	MB 25 L:	350 to 2500°C	3 876 400	3 876 410

Ordering note: When ordering please specify as follow: - one focusable optics
- if required the adjustment of a sub range
- analog output 0 to 20 mA or 4 to 20 mA

Notes: A connection cable for power supply and analog output is not included in scope of delivery and has to be ordered separately.
The Profibus cables have to be provided by the customer.

Ordering example: 3 875 150 IS 140 with thru-lens view finder, focusable optics 2, temperature range 650 to 1800°C
3 821 080 connection cable, length 10 m, with 90° connector

Scope of delivery: Pyrometer with focusable optics, diskette with GSD-file

IS 140-PB; IGA 140-PB

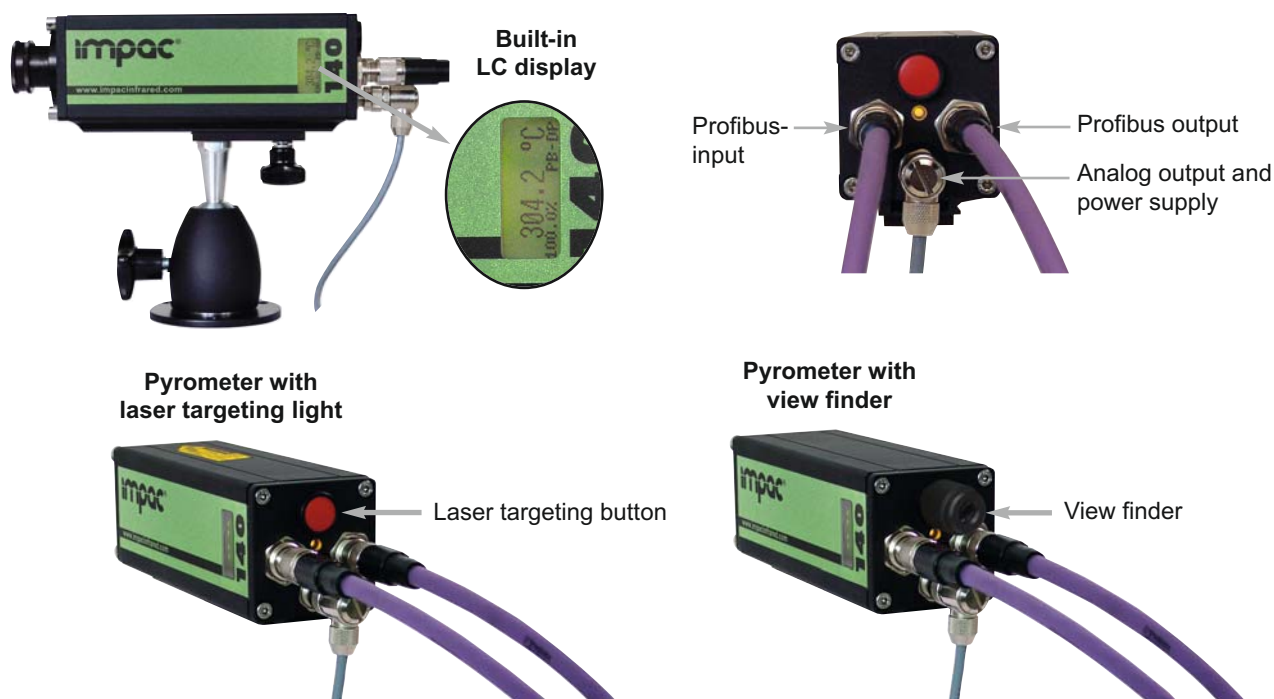

Reference Numbers Accessories

Accessories:

3 820 340	connection cable, length 5 m, 90° connector	3 834 200	ball and socket mounting for cooling jacket
3 820 530	connection cable, length 10 m, 90° connector	3 837 240	cooling plate
3 820 540	connection cable, length 15 m, 90° connector	3 835 450	90° mirror with quartz glass window
3 820 830	connection cable, length 20 m, 90° connector	3 843 520	rugged scanner SCA 140, (scanning angle adjustable 0 ... 12°, scanning frequency adjustable 1 ... 5 Hz), with quartz glass window
3 820 840	connection cable, length 25 m, 90° connector		
3 820 550	connection cable, length 30 m, 90° connector	3 835 290	air purge for scanner SCA 140
3 820 330	connection cable, length 5 m, straight connector	3 852 290	Power supply NG DC for DIN rail mounting; 100 to 240 V AC ⇒ 24 V DC, 1 A
3 820 500	connection cable, length 10 m, straight connector		2 limit switches
3 820 510	connection cable, length 15 m, straight connector	3 890 640	LED digital display DA 4000-N
3 820 810	connection cable, length 20 m, straight connector	3 890 650	LED digital display DA 4000: with 2 limit switches
3 820 820	connection cable, length 25 m, straight connector	3 890 560	LED digital display DA 6000-N: with possibility for pyrometer parameter settings for digital IMPAC pyrometers; RS232 interface
3 820 520	connection cable, length 30 m, straight connector		
3 820 740	connection cable, length 5 m, straight connector, temperature resistant up to 200°C	3 890 520	LED digital display DA 6000; DA 6000-N additional with 2 limit switches and analog input and output
3 820 750	connection cable, length 5 m, 90° connector, temperature resistant up to 200°C	3 826 500	HT 6000, portable battery driven indicator and instrument for pyrometer parameter setting
3 820 430	Video cable with cinch connector and adaptor to SCART, 5 m long (optional 10 m, 15 m, 30 m)		
3 834 280	adjustable mounting angle		
3 834 270	ball and socket mounting		
3 835 230	air purge		
3 837 290	cooling jacket, stainless steel		
3 835 060	air purge for cooling jacket		

Accessory only for IS 140-PB; IGA 140-PB:

3 821 070	connection cable (cables for power supply and analog output), 5 m, with angled connector	3 821 090	connection cable (cables for power supply and analog output), 15 m, with angled connector
3 821 080	connection cable (cables for power supply and analog output), 10 m, with angled connector	3 821 100	connection cable (cables for power supply and analog output), 30 m, with angled connector

Overview Accessories

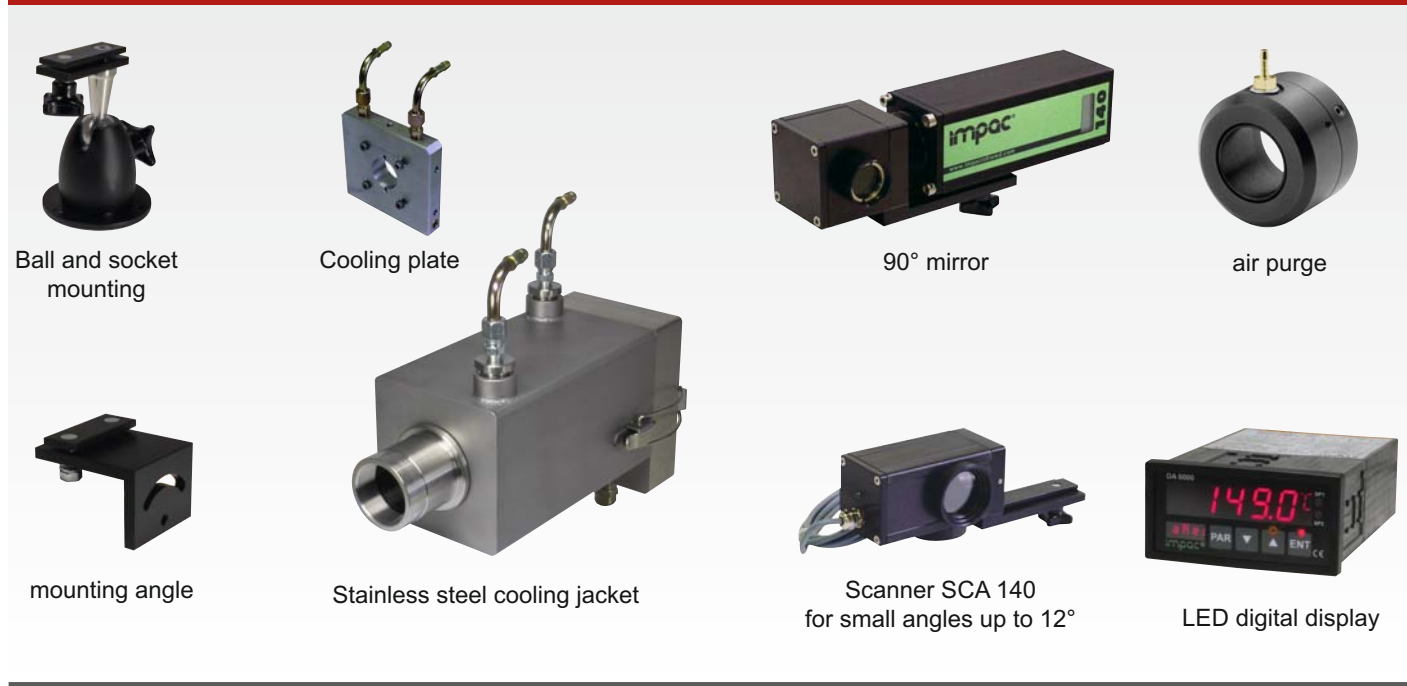

LumaSense Technologies

Americas and Australia

Sales & Service
3301 Leonard Court
Santa Clara, CA 95054
Tel.: +1 408 727-1600
Fax: +1 408 727-1677

info@lumasenseinc.com

Europe, Middle East, Africa

Sales & Service
D-60326 Frankfurt, Germany
Kleyerstr. 90
Tel.: +49 69 97373-0
Fax: +49 69 97373-167



ASRAS CO.,LTD.
1694, 1694/1 Prachasongkhro Road,
Dindaeng, Dindaeng, Bangkok 10400
Tel. 02-692-3980, Fax. 02-692-3978
E-mail: sales@asras.com
www.asras.com; www.asras.co.th